



Lite Cruiser
Personal Mobility Aid



Standard Model

Website: www.EZLiteCruiser.com

E-mail: support@ezlitecruiser.com

Phone (Toll Free): 1-(888) 544-6054

PRECAUTIONS

Thank you for purchasing the EZ Lite Cruiser. We sincerely hope that it will bring convenience and enjoyment to your daily life.

Please read the instructions before using the chair in order to operate and maintain it properly. EZ Lite Cruiser assumes no responsibility for personal injury or property damage sustained by or through the use of this product. By using the product, you agree to indemnify EZ Lite Cruiser from any injuries sustained from and during use, regardless of fault.



Please pay attention to the followings content with these warning symbols. Failure to take precautions could result in serious injuries. It can also damage or decrease the life expectancy of the EZ Lite Cruiser.



WARNING



DON'T DO THIS



ASSISTANCE



TABLE OF CONTENTS

Front Cover.....	1
Precautions.....	2
Identification of Components.....	4
Safe Usage Guide.....	6
Battery Guide.....	11
Charging Guide	12
Using Two Batteries	15
Powered & Manual Mode Operation	16
Safety Tips	17
Transport, Storage & Maintenance	18
Quick Start Guide	19
Helpful Links Online.....	26
Joystick Information.....	27
Fault Indicators.. ..	28
Troubleshooting Guide.	29
Specifications.	30
Service History.....	31
Warranty Information.....	31
Back Cover.....	32

IDENTIFICATION OF COMPONENTS

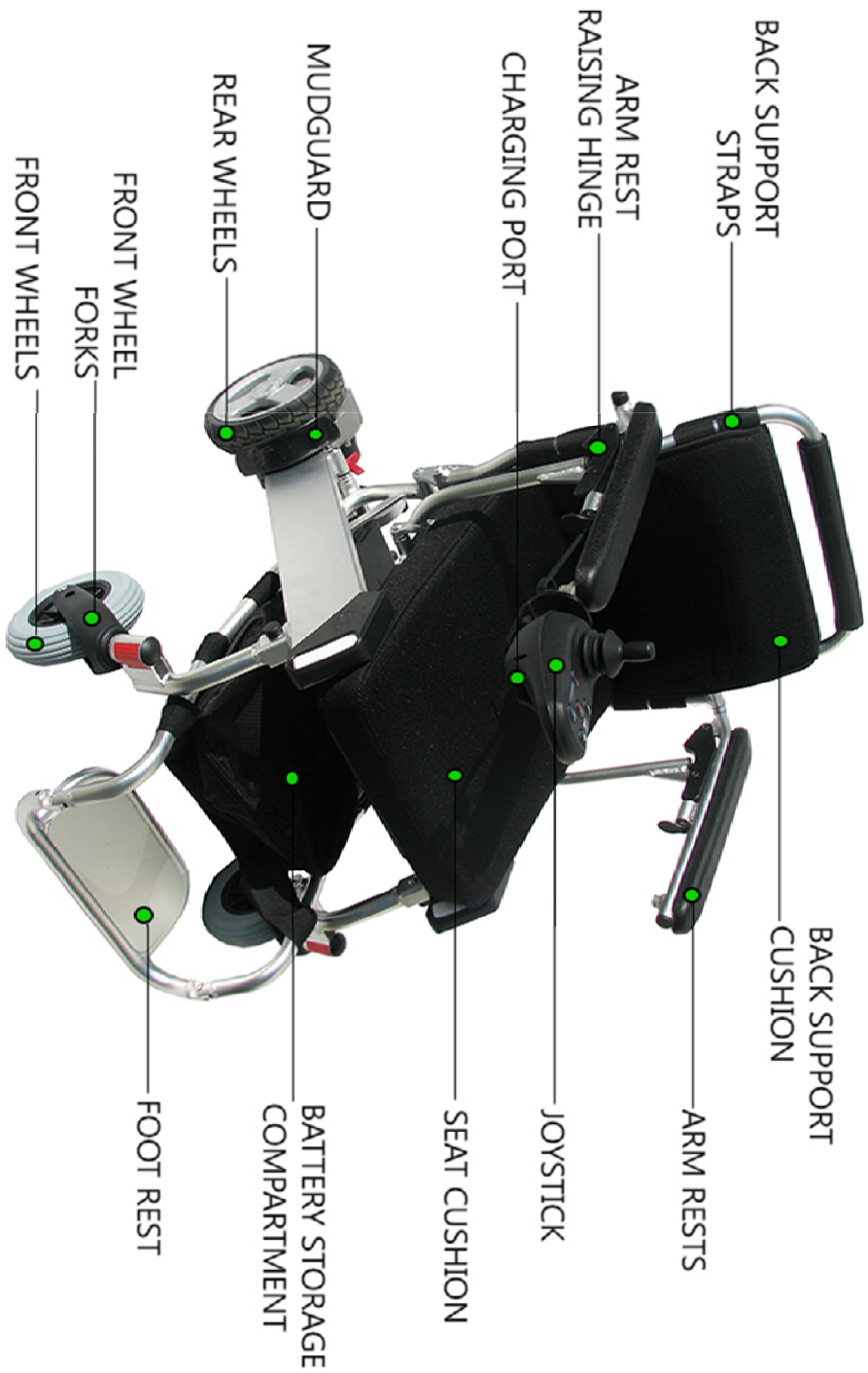

* Front and Rear Wheels May Vary in Color.

IDENTIFICATION OF COMPONENTS



* Front and Rear Wheels May Vary in Color.

SAFE USAGE GUIDE

BEFORE DRIVING — READ THIS SECTION CAREFULLY.



The user must be of sound mind and judgment. They must be conscious and have unimpaired motor functions in their hand to use the controller. The user must read this user's guide before operating the chair and get familiar with its components and features.



The user should practice driving skills with assistance on open, flat, and safe grounds before normal use.

Moving Forward and Stopping

- To move forward, push the joystick forward lightly.
- To stop, release the joystick.
- Learn to drive consistently without releasing the joystick too often, which may cause a jerky feeling while driving.

Moving Backwards

- To move backwards, push the joystick backwards lightly.
- The user must be aware of what is behind them before maneuvering backwards to avoid collisions.

Turning in Place

- To turn, push the joystick to the left or right.
- The user must be aware of what is to the left or right to avoid collisions when turning.

SAFE USAGE GUIDE

Driving on Bends or Windy Paths



- Lightly push the joystick in the direction of the bend.
- Practice speed control.
- Avoid making sharp or hard turns. Sharp or hard turns are only to be done when the chair is already in a stopped position.



Practice Avoiding Obstacles

- Lightly push the joystick in either directions to avoid and maneuver around the obstacle/s. Again, practice speed control.



Driving Faster

- Push the joystick all the way in the direction you want to go. Release the joystick back to the middle/center if you do not feel you are not 100% in control.

Driving Over Small Curbs and Thresholds



- Lightly push the joystick and drive slowly over the curb. The **threshold should not be higher than 1.25 inches of a vertical**. If you're having trouble getting over a threshold, attempt it while driving in reverse, but only do so with assistance when attempting for the first few times.

SAFE USAGE GUIDE

Driving Uphill



- Keep your body tilted forward to keep the center of gravity stable. Drive slowly and calmly.
- We recommend the slope be less than 8 degrees for optimal performance.

Driving Downhill



- Make sure the electromagnetic brake is engaged before driving downhill.
- We recommend the slope be less than 8 degrees for optimal performance.
- Drive all the way through a decline and stop on flat area.

Limit Driving to Sidewalks



- The user should stay on the sidewalk and avoid entering the street or anywhere there is a motor vehicle lane, unless it is to cross the street. Pay attention to obstacles and avoid contact with them.

Crossing the Street



- Pay attention to traffic signals, posted signs and avoid motor vehicles. Only cross when you are allowed to.
- Drive slowly over the curb, to get back on the sidewalk, which should not be more than 1.25 inches high.
- Prior to crossing, make sure you have sufficient battery power to avoid stopping in the middle of the street.

SAFE USAGE GUIDE

Entering & Exiting an Elevator



- The user should pay attention to the opening and closing intervals of the elevator door to avoid a collision while entering or exiting the elevator.

Driving over Train or Railroad Tracks



- We highly discourage you from ever crossing railroad/train tracks alone in the EZ Lite Cruiser. You should be accompanied by an assistant, friend, or loved one.



- Attempting to cross tracks that are elevated too high (more than 1.25 inches) could result in a rollover or accident. It could endanger the personal safety of the user.

Driving over a high curb/step or steep incline.



- Driving over too high of a curb/step (more than 3cm) could result in rollover.
- Driving on too steep of an incline could also result in a rollover.

Transferring Into and Out of the EZ Lite Cruiser



- We recommend that the user has assistance getting into and out of the seating area.
- Move the arm rests and foot rest out of the way before entering and exiting the chair.

SAFE USAGE GUIDE



Seat Belt

- We recommend using the seat belt.

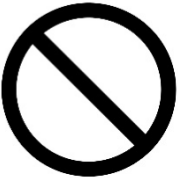

Self Repair of the EZ Lite Cruiser

- Avoid attempting to repair the product on your own. It may cause permanent damage to the chair and could put yourself at risk of injury.
- We strongly recommend that the product should be repaired by a professional repair shop or maintenance service personnel.



Contact With Water



- DO NOT hose down (Spray) the chair with water or any liquids. It will cause damage to the chair.
- For overall cleanliness, wipe the chair down with a damp cloth.
- The seat cushion could also be removed to be washed separately.



Usage in the Rain or Snow

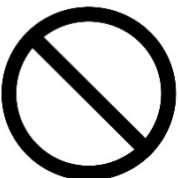

- Avoid using the chair in any precipitation. Heavy down-pours should be avoided at all costs.
- It may cause damage to the chair. Cover the chair with a poncho in case of the possibility of rain.
- Usage in snow and wet ground may cause wheels to lose traction & slip. If necessary to use it in precipitation, please do it with the assistance of another person.



BATTERY GUIDE

Battery Handling and Care



- DO NOT leave the battery in direct sunlight. It will cause permanent damage, or a volatile reaction. Store the battery in a cool, dry area.



- DO NOT remove ANY wrapping, whether it is blue, clear, plastic or otherwise, from the battery pack.



- DO NOT allow children access to the battery or electrical components of the chair.

- DO NOT place any items on the charger while charging.

- DO NOT store in a severe cold environment. It will damage and decrease the life of the battery.

- Keep the battery away from fire and heat sources.



- If the battery becomes hot, deformed, or emits an odor while charging, stop the charging immediately.

- The charger may get slightly warm when charging, this is acceptable. The charger should not get overly hot where it is uncomfortable to the touch, and it should never emit smoke or fire.



- The battery can be safely charged overnight. It is equipped with overcharge protection by way of a Battery Management System (BMS).



- Fully charge the battery in case of storage. The battery has discharge characteristics and must be charged once every month or it could lead to over discharge damage, and cease functioning. **Failure to do this will void warranty.**



- Our Lithium Batteries are recyclable. Please discard them responsibly through a local recycling facility.

CHARGING GUIDE

General Information on Charging the Battery



- Please use the Lithium battery charger supplied by EZ Lite Cruiser and **never use a charger from another power chair!**
- **Unless instructed by an EZ Lite Cruiser Technical Support technician, DO NOT turn on the controller power or use the chair during charging.**



- Ensure that the battery is cool while charging. The charger may get a little warm while charging, due to current running through it. The charger should never get HOT to the touch. Please check it periodically. Failure to check can cause damage to the chair and even start a fire.



- Charging time can vary from 2 to 8 hours, depending on the level of the battery when charging has started, and the capacity of the battery you are charging.



- The charger can be used overnight safely.
- The charger must be disconnected from the joystick in order to operate the EZ Lite Cruiser.



- Keep charger away from moisture and impact.
- **The charger for the EZ Lite Cruiser operates at voltages between 100 - 240 Volts AC input, meaning it will work overseas in any country where the wall outlets provide between 100 to 240 Volts.** You will simply need to change the shape of the wall outlet plug using a common adapter to change the plug to match shape of the outlets for the country you are using the EZ Lite Cruiser in.

CHARGING GUIDE

Charging the Battery “On Board”



- “On Board” charging means the battery is connected to the EZ Lite Cruiser’s Power Input connection, to supply the chair with power. First, Plug the battery in to the chair.



- Next, Insert the charger into an electrical outlet, which will cause the charger light to turn on. The light will be **Green**.



- Lastly, Insert the charger round metal tip into the Joystick.



- **GREEN** Indicator light means either that the battery charging has finished, or is taking a break** (see below). *It can also mean that there is no battery connected!*



- **RED** Indicator light means that the battery is charging.

- ** If you are patient and watch the battery charging, you may notice that the charger light will change from **Red** (charging) to **Green** (not charging) and shortly thereafter back to **Red** (charging)..... **Green** (not charging), **Red** (charging), etc. The reason this will change many times is that the charger is going through all of the 8 cells in the battery pack and charging each one individually. Please be patient and wait for the charging to be completed fully. Before disconnecting the charger. Disconnecting it too quickly at the first **Green** light on the charger may be a false-positive indication that charging has completed, when in actuality it has not!

- **When you see that the light on your charger has remained Green for at least 30 minutes, that is when you know the battery charging has completed.**
- See the PHOTO at the bottom of Page 24 in the Quick Start Guide Section.

CHARGING GUIDE

Charging the Battery “Off Board”



- “Off Board” charging means the battery is NOT connected to the EZ Lite Cruiser’s Power Input connection, and it is not supplying the chair with power.



- In this scenario, you will first connect the charger into an electrical outlet, which will cause the charger light to turn on. The light will be **Green**.



- Lastly, Insert the charger round metal tip into the matching round metal tip connector on your battery.
- The same principles for the lights on the charger changing numerous times, as described on the previous page for “On Board” charging, will apply in this scenario.
- See the PHOTO at the top of Page 25 in the Quick Start Guide Section.

Charging Two Batteries At the Same Time

- **It is NOT possible to charge Two Batteries with One charger at the same time.** If you have TWO batteries that you’re using together, with the Dual Battery Connector, you must **DISCONNECT the batteries from the Dual Battery Connector, & charge each one SEPARATELY. This is VERY IMPORTANT.** If you charge both batteries with the Dual Battery Connector, you are **ONLY CHARGING ONE BATTERY AND MAY CAUSE A FAILURE OF YOUR SECOND BATTERY, which will void the battery warranty.**
- You can charge Two Batteries at the same time, if you have a second charger, and you charge the batteries separately. You can charge one On Board, and one Off Board, OR both Off Board (easier.)

USING TWO BATTERIES

Using the Dual Battery Connector Cable



- You can connect and use Two batteries at the same time. The power will be drawn from both batteries. In order to do this, you must have purchased a second battery (your chair only comes with one) and a Dual Battery Connector.
- As described on the previous page (Page 14), charging two batteries together with the Dual Battery Connector cable is not possible. **Each battery must be charged individually.**

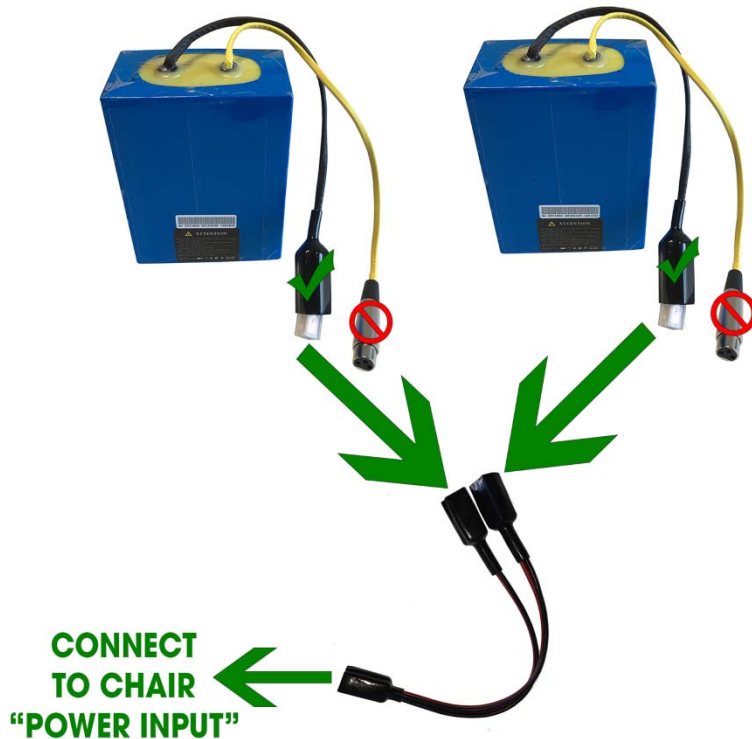

- Two 10 Ah Batteries are shown in the illustration above.. The same methodology for connection applies to Two 15 Ah Batteries. All connections are made in the same way.

POWERED & MANUAL MODE OPERATION

Using in the Powered (Electric) Mode

- Flip the red levers (the electromagnetic locks, identified in the components of the EZ Lite Cruiser on page 5) on both of the rear wheels and ensure that the wheels are locked in place, and are not moving at all.
- When the chair is powered electrically, the chair can not be pushed manually.
- After the user is seated in the chair, turn on the power.
- Pushing the joystick forward to go forward.
- Pulling joystick back to go back.
- Pushing joystick left to turn left.
- Pushing joystick right to turn right.
- The chair will go faster when the magnitude is greater.
- Release the joystick to stop the chair.
- Press the power off button to shut down the power.

Using in the Manual Mode



- Ensure that the power is OFF.
- Flip the red levers (the electromagnetic locks, identified in the components of the EZ Lite Cruiser on page 5) on both of the rear wheels. This will allow you to roll the wheels manually.



- If one of the wheels rolls and the other does not, flip the red lever to the same position as the wheel that does roll. If neither wheels roll, flip the red levers to the opposing position for both wheels. You will hear a 'clunk' noise when the lever is flipped.



- If the user operates the chair without assistance, the electromagnetic brake must be at the engaged position. Otherwise, the user will not have control over the chair.

SAFETY TIPS

Additional Warnings & Precautions



- If the EZ Lite Cruiser is not locked in the open position, it can collapse when attempting to sit on the chair. This can cause damage to the chair and also hurt the user. Please ensure that the chair is fully unfolded before sitting in it.



- Check, double-check and triple-check to make sure the chair is opened all the way and locked into position.



- If the front wheel is not in the proper position the chair will not fold tightly and could cause damage. Make sure the front wheels are in the correct position before closing.



- The cable should be around armrest in order to avoid pulling on the joystick.



- Watch to ensure the joystick cable is not caught between any metal frame parts of the chair as they come together.



- DO NOT use the joystick unless you are sitting in the chair.
- DO NOT disconnect any plugs by pulling on the wire. Only disconnect by pulling on the plugs near the sockets to prevent damage to the wiring. Any plugs should be unscrewed before they are pulled on.

- DO NOT DRINK AND DRIVE. Operating the chair is prohibited while intoxicated. Failure to comply could lead to serious injury or even death.

TRANSPORT, STORAGE & MAINTENANCE

Transport & Storage

- To pick up the chair, stand it up when it is folded. Lift the chair by metal frame parts always, never by any cushions, straps or plastic parts.
- The battery should be fully charged and the chair should be placed in cool, dry, and ventilated place in case of the chair will long-term placement.
- The battery needs to be charged once every two months, otherwise it could lead to over-discharge damage.
- Avoiding storing the chair around heat, cold or direct sunlight. The rubber parts will age quicker and shorten the service life.
- The battery is very sensitive to high temperature environments and to pressure. Avoid high temperature and pressure, as it may cause a fire.
- There are electronic components in the joystick. Avoid pressing and putting too much pressure on it

Service & Maintenance

- Periodically (every 6 months or so) check the frame screws to see if they are loose & tighten them as necessary
- Check if the front and rear wheels are rotating easily. If there is significant resistance, please change the bearing.
- Check if the tires, armrest and other rubber and plastic parts are wearing. Replace them accordingly.
- Check if the folding locks work. If it is loose or jamming, please replace it promptly.
- Check the anti-tip wheels/device. If it is loose or jamming, please replace it promptly.
- Parts replacement should be done by professional repair shop or maintenance service personnel. DO NOT replace them by yourself.



QUICK START GUIDE

YOU MUST read all of the information on the previous pages before starting to use your EZ Lite Cruiser. The previous pages contain extremely important safety information, proper usage, care & maintenance of your EZ Lite Cruiser. Failure to read the information can lead to problems that will not be covered under your warranty, due to user error.

After reading the previous pages, continue reading this Quick Start Guide:

Battery Outer Packaging

Please **DO NOT** remove the **Blue Plastic Wrap OR the Clear Plastic Wrap** (applies to the 10 Ah Batteries) that makes up the outer packaging of your battery! This will expose the inner workings of the battery and can be dangerous.

Battery Storage

The battery can be kept in the fitted black pouch that came with it, at all times. This fitted pouch is convenient for carrying the battery when disconnected.

Battery Charge Level Upon Arrival

When you receive your battery, it is almost fully charged! You can begin using your chair right away to test it out. Before driving it intensively, we recommend charging the battery back up to full.

Charging the Battery

The chargers (regular or Speedy) for the EZ Lite Cruiser by default has a round metallic tip that will plug into the front of the joystick. With this arrangement, the charging will occur through the joystick, down to the battery. Your battery will also have a second circular round metallic tip connector, which will allow the charger to plug into them directly, allowing you to charge the battery off-board. **See page 13 for details for On Board charging, and page 14 for details for Off Board charging.**

QUICK START GUIDE

Charging Two Batteries

You can not charge two batteries at the same time using the dual battery connector. For more information on charging two batteries, see page 14. To charge two batteries, the easiest way is to have two chargers and charge each battery Off Board. Or Charge one battery On Board and one battery Off Board, but you will still need a second charger to do this. If you have one charger, you can charge one battery first, and charge the second battery when the first one is done.

Red Levers on the Rear Wheels

The red levers on the rear wheels control the electromagnetic lock and ultimately the braking system. **The levers must be ENGAGED** in order for you to use the chair in the powered mode.

How do you know if they are engaged? **This is a “Sanity Check” :**

- When the device is powered OFF, and they are DISENGAGED, then you will be able to roll the rear wheels manually by pushing the chair.
- When the device is powered OFF and they are ENGAGED, you will not be able to roll the rear wheels manually.
- When the device is powered ON, the locks must be ENGAGED in order to drive it. If they are not engaged, the joystick will flash the top light on the speed setting, indicating this fault.

Seat Belt

The seat belt is located in the zippered compartment underneath the seat. For help with mounting the seat belt, we have a video showing the process. Please visit <http://www.ezlitecruiser.com/help7>

Toolkit

The toolkit is located in the zippered compartment under the seat. Every few months, you should check the joints of the chair and tighten any hinge joints on which the chair folds. Failure to do this can cause loose bolts, breakage and void the frame warranty. Upkeep is essential.

QUICK START GUIDE

Keep it Clean & Take Good Care of Your EZ Lite Cruiser

The key to a long life out of the EZ Lite Cruiser, like anything else, is to keep it clean and take good care of it. Keeping it clean will keep it looking like new again,. Taking good care of it will ensure the longest life possible out of it. This may mean occasionally performing service & maintenance to keep it running like new. Please contact us if you have any questions or need help finding a shop in your area that can perform service or maintenance on your EZ Lite Cruiser.

Now, let's start working with the EZ Lite Cruiser and its components....



Unboxing the EZ Lite Cruiser

When you take the chair out of its box, and remove any packaging materials from around it, this is what the chair will look like. You will be able to stand it up on the rear wheels, and it will balance itself in the upright position. Notice the top most metal beam underneath the seat cushion, you will use this to get it unfolded.



Get It Unfolded

Place one hand at the front/base of the seat (metal part of the frame) and lower that end towards the ground. At the same time, lift up by the back support bar, and it will unfold. If you're having trouble, watch the videos we've prepared. When done correctly, you will hear it lock into place when it is fully unfolded. Make sure it is fully unfolded before sitting down.

QUICK START GUIDE



Engaging the Electromagnetic Locks

You must do this to use the chair in the powered mode. It also prevents the chair from rolling manually. You will flip the levers BACKWARD (away from the chair) to engage the locks, or FORWARD (towards the chair) to disengage the locks when needed. When disengaged & the power is OFF, the rear wheels will roll freely. When engaged, they won't roll.



Mounting the Joystick

Insert the joystick mounting fork end into the desired arm rest, and then secure it with the fastening bolt underneath the arm rest. To move the joystick to the left side, you simply need to move the wiring along with the fastening bolt to the left side and secure the joystick there.



Put Battery in the Fitted Carry Case

Your EZ Lite Cruiser battery comes with a fitted (small) carrying case designed specifically for the battery, so you can easily disconnect it and carry it with you. You shall store the battery in this fitted case for convenience, and the battery can be kept in this fitted case at all times, without any concern.

QUICK START GUIDE



Connect the Battery

To connect the battery, simply plug in the male power/input connector on-board the EZ Lite Cruiser into the female end of the connectors on the battery. The connectors can only match one way and you will hear a clicking noise when it is firmly connected. If you did not hear a clicking noise, disconnect it and try it again, but it may be a faint noise.

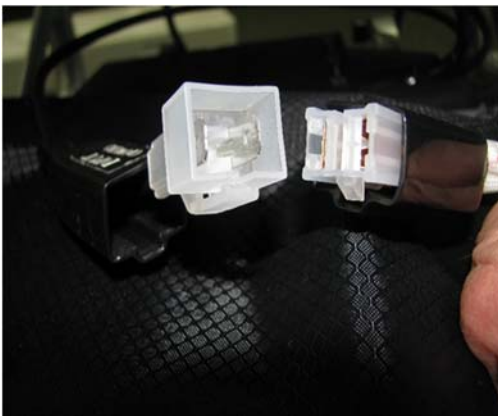

Battery Connection Detail

Notice the tooth on the battery connector part and the raise-able clip on the power input connector. These two connection points must align in order to properly connect the battery. When they're connected, you can push the black plastic covers over each connector until they meet. They will not overlap.



Properly Connected Battery

When you make a proper connection between the battery and the power input, you will hear a soft click noise indicating it was connected, and the tooth on the battery plug will be latched in securely in the clip on the input plug.

QUICK START GUIDE



Improperly Connected Battery

Make sure the connection between the plugs is tight and secured. If you do it right, you will hear a soft click indicating that the connection has been met. If you do it wrong, there will not be a click noise, and the connectors will not be together, so you will not have power to your chair!



Storing the Battery

The battery will be stored in the zippered bag found directly underneath the seat. Simply unzip the compartment, and place the battery inside there. You can also store the Charger in this same compartment — there is enough room for it along with the battery.



Charging the Battery On Board

To charge the battery On Board, with it connected to the chair, make sure the battery is still connected underneath the seat to the “Power Input” plug. Then, connect the round metal tip of the charger into the front of the joystick. Make sure the Power is OFF on the Joystick.

QUICK START GUIDE



Charging the Battery Off Board

You also have the option of charging the battery outside of the chair. Simply connect the charger to an electrical outlet, and then connect the metal round tip of the charger directly to the battery, to the matching metal round tip that is on the battery. This is called Off Board charging.



Folding the EZ Lite Cruiser

Pull on the wire located on the back of the chair with one hand, and push down on the top of the back support towards you & the ground, gently. Release the wire once the chair begins to fold. Then continue to push down on the back support until the chair folds all the way. The chair will collapse completely until it is flat. You may have to adjust the front wheels to tuck them away nicely.



Lifting the EZ Lite Cruiser

Use the metal beam located underneath the front of the seating area. Lift with one hand if you are capable of doing so. If not, you can lift with a second hand using another metal beam located in the back side (bottom) of the chair, to make it easier. Never lift by any cushions or plastic parts.



HELPFUL LINKS ONLINE

We have a number of videos online to help you get started.

Unfolding

Visit: <http://www.ezlitecruiser.com/help1>

Alternate Method, Visit: <http://www.ezlitecruiser.com/help2>

Connecting The Battery

Visit: <http://www.ezlitecruiser.com/help3>

Mounting The Joystick

Visit: <http://www.ezlitecruiser.com/help4>

Folding

Visit: <http://www.ezlitecruiser.com/help5>

Using Accessories

Visit: <http://www.ezlitecruiser.com/help6>

If there is something you don't know how to do, please visit the website and browse our **Frequently Asked Questions** page, or **Contact Us**, and we will be glad to help.

Website: www.EZLiteCruiser.com

E-mail: support@ezlitecruiser.com

Call Toll Free: 1-800-544-6054 or **Internationally** +1.310.2954422



Additional videos are available on our YouTube Page:

<http://www.youtube.com/ezlitecruiser>





JOYSTICK INFORMATION



Function		Description of Functionality
1	Power On Button	Pressing this button will power on the EZ Lite Cruiser
2	Power Off Button	Pressing this button will power off the EZ Lite Cruiser
3	Speed Increase Button	Pressing this button will increase the speed of the chair, and illuminate the Speed Indicator LEDs until all 5 lights are illuminated (top speed.)
4	Speed Decrease Button	Pressing this button will decrease the speed of the chair, and turn off each light of the Speed Indicator LEDs until only one light is illuminated (lowest speed.)
5	Horn	Pressing this button will sound the horn.
6	Battery Life Indicator LEDs	This indicates the battery level. 3 Green, 3 Yellow and 1 Red LED light will be on with full power. As power is diminished, each light from top to bottom will turn off.
7	Control Joystick Knob	Controls the direction and speed of the EZ Lite Cruiser. Push the joystick towards the desired direction.
8	Speed Indicator LEDs	With 5 LED lights on, the EZ Lite Cruiser is set at its max speed. With 1 LED light on, the EZ Lite Cruiser is at its lowest speed. This panel also doubles as a Fault Indicator.

FAULT INDICATORS

Aside from indicating the speed setting of the EZ Lite Cruiser, the Speed Indicator LEDs (number 8 on the figure shown on the previous page) acts as an indicator of common faults in the controller system. When these LEDs flash with the following Display as indicated below, the most common problems and their respective possible solutions are identified:

Display	Problem	Solution
	Battery power is low.	You must recharge or replace the battery.
	Joystick cannot deliver signals to the control module (CPU)	Check to see that all cable connections are firmly attached. If they are, this would indicate a problem with the joystick, and it may need to be replaced with a working joystick. Joystick wire could be cut.
	An electronic drive locking function is engaged to prevent the EZ Lite Cruiser from being operated. Also acts to indicate that the battery is being charged.	Disconnect the 3-pin Charger cable from the front of the Joystick component. If it is disconnected, this would indicate a problem with the Joystick's Charger connector I/O port.
	Brushless motors fail to move.	Check to see that all cable connections are firmly attached. If they are, this would indicate an open or short circuit somewhere in the controller system. Use a multimeter to detect an open or short circuit.
	Electromagnetic lock on rear wheels is disengaged.	Push the electromagnetic levers on the rear wheels back towards yourself (when standing behind the EZ Lite Cruiser) to engage the electromagnetic lock.

TROUBLESHOOTING GUIDE

#	Problem	Reason	Solution
1	Power won't turn on	<ul style="list-style-type: none"> • Controller host power is not connected • Controller host and joystick are not connected • Battery power is too low 	<ul style="list-style-type: none"> • Connect host power • Connect four core plug with joystick • Charge the battery
2	Flashing red lights on Joystick Controller	<ul style="list-style-type: none"> • No.1 Red Light Flash: Low Battery • No.2 Red Light Flash: Joystick is without communication signal • No.3 Red Light Flash: In Charging • No.4 Red Light Flash: The motor is not connected • No.5 Red Light Flash: Electromagnetic Brake is not connected 	<ul style="list-style-type: none"> • Charge the battery • Connect four core plug with joystick or replace joystick • DO NOT turn on or operate the chair during charging • Insert motor cable and tighten the plug • Insert motor cable and tighten the plug
3	Vibration and noise while chair moving.	<ul style="list-style-type: none"> • Limited Max speed is too low • The motor is damaged 	<ul style="list-style-type: none"> • Adjust the max speed • Replace the motor
4	Endurance mileage is shortened	<ul style="list-style-type: none"> • At below 0 degrees Celsius • Driving on uneven pavement or slope 	<ul style="list-style-type: none"> • This is normal characteristics of the battery • Energy consumption will increase on uneven pavement and slopes. This is normal.
5	Battery Charging Faults	<ul style="list-style-type: none"> • Charger light doesn't go on • Charger light is always green • Charging time is shorten 	<ul style="list-style-type: none"> • Replace the Charger • Four core plug is not connected with the joystick or replace the battery • Capacity has decreased, replace the battery



SPECIFICATIONS—STANDARD MODEL

Parameter	Value
Device Weight	44.6 lbs
Max Capacity	265 lbs
Unfolded Dimensions	31.5" x 22.4" x 33.1"
Folded Dimensions	28.5" x 22.4" x 12.25"
Seat Dimensions	16.75" x 15.25"
Seating Height	20" (from ground)
Turning Radius	29.25"
Maximum Speed	Up to 5 mph
Battery Type	LiFePO4 Lithium Battery
Distance on Full Battery	10-15 miles
Ground Clearance	3.9"
Front Wheels	7" x 2" (Diameter x Width)
Rear Wheels	8" x 2" (Diameter x Width)
Incline Capability	20% slope (12°)
Wheel Material	Polyurethane & Rubber
Motor Type	2 x 180 Watt Brushless HUB Motors
Charger Type	Input: AC 100-240V ~1.8A Max 47Hz-63Hz Output: DC29.2V~2A
Brake Type	Electromagnetic

SERVICE HISTORY

Date	Description of Service

WARRANTY

Part	Coverage	Remarks
Frame	10 Years	Non-deliberate damage
Motor	5 Years	Non-deliberate damage
Battery	2 Years	Non-deliberate damage
CPU	2 Year	Non-deliberate damage
Joystick	2 Year	Non-deliberate damage
Wearing Parts	3 Months	Tire, Seat, Backrest, Armrest



Lite Cruiser
Personal Mobility Aid



Website: www.EZLiteCruiser.com
E-mail: support@ezlitecruiser.com
Phone (Toll Free): 1-(888) 544-6054

The information provided in this user manual is copyright © 2015 by EZ Lite Cruiser. Any use of this information for any purposes outside of demonstrating the use of the EZ Lite Cruiser is strictly prohibited .